

OVERHEAD CONVEYORS

LUBRICANTS



LUBRILOG
LUBRILOG

LUBRICATION ENGINEERING

WWW.LUBRILOG.FR

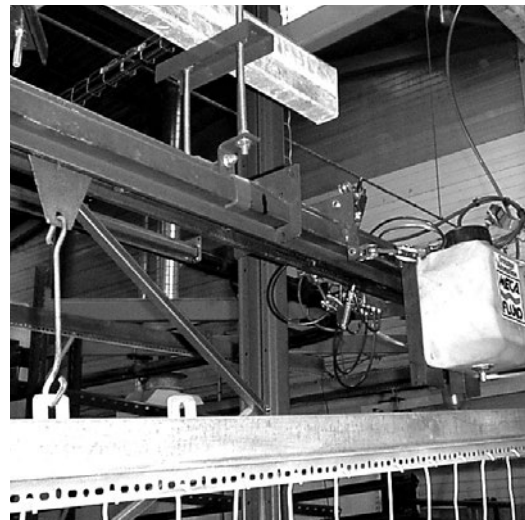
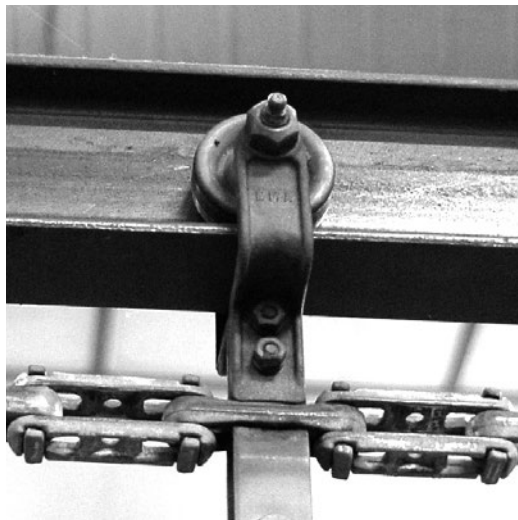
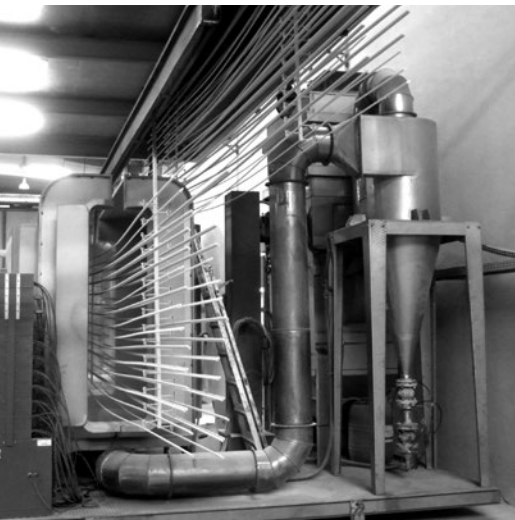
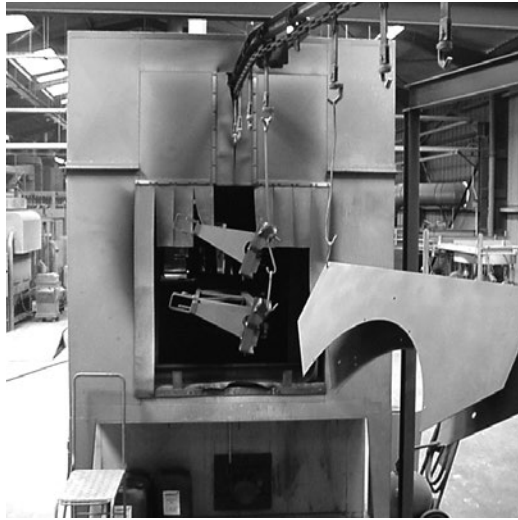

WWW.LUBRILOG.FR

OVERHEAD CONVEYOR LUBRICANTS

An overhead conveyor consists of a single track containing carrier trolleys connected by an endless chain. Typical overhead conveyor applications insure product flowing through finishing operations such as paint booth, dip tank, plating operation, assembly line, etc...

LUBRILOG has developed a full suitable lubricant range dedicated to conveyor system to match technical and economical end users expectations. Our special lubricants perform in any conditions even in the extreme ones.

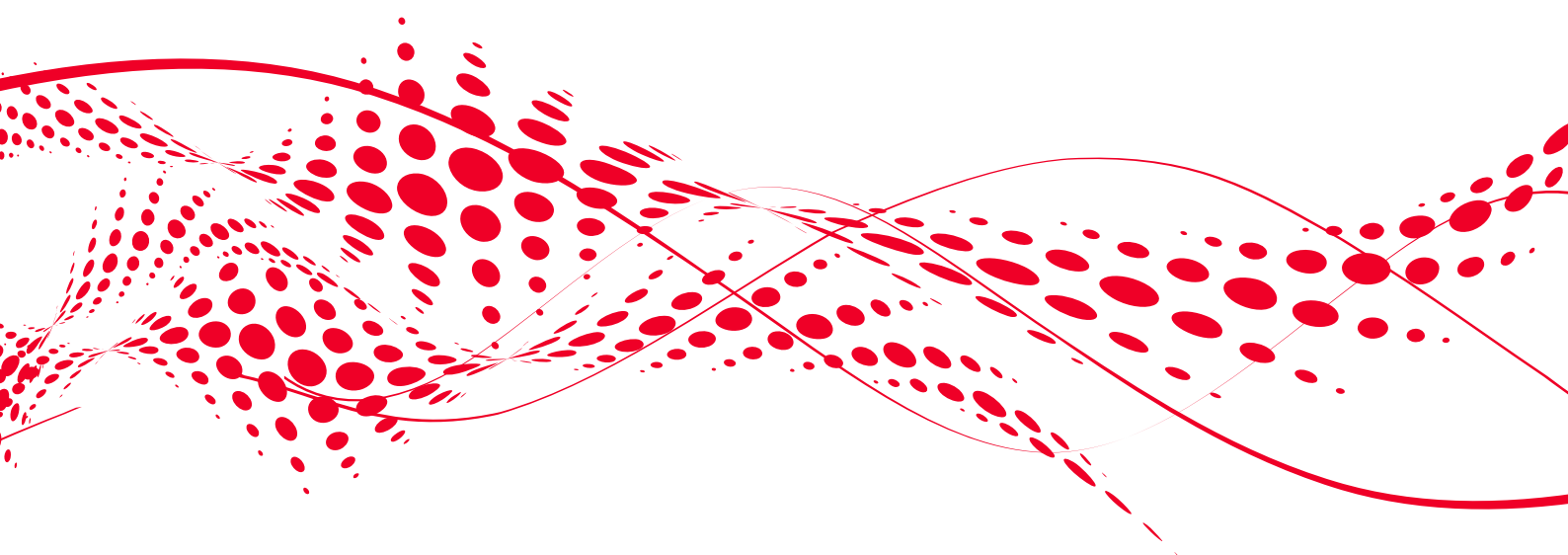

LUBRICANT SPECIFICATIONS

LUBRICANT CHARACTERISTICS

Reference	Nature	Operating temperature range	Application	Benefits
FLUOSTAR H 2 PLUS	Synthetic PFPE grease NLGI Grade 2	- 30 to 260 °C	First lubrication & Relubrication	Very high resistance to high temperature. Longer lubrication intervals. No coking residues.
FLUOLOG K 400	Synthetic PFPE Grease NLGI Grade 2	- 30 to 260 °C		
FLUOLOG K 500	Synthetic PFPE Grease NLGI Grade 2	- 40 to 280 °C		
FLUOSTAR SX 3	Synthetic PFPE Grease NLGI Grade 3	- 60 to 300 °C		
FLUOSTAR CHAIN 320	Synthetic PFPE oil 320 mm ² /s viscosity	- 40 to 300 °C	Automatic (spraying or drop systems). Manual lubrication.	Very high resistance to high temperature. Longer lubrication intervals. No coking residues.
STARPLEX G 2	Premium quality lithium complex grease	- 20 to 150 °C	First lubrication & Relubrication	High thermal stability. Good resistance to water. Anti-wear, Anti-corrosion.
LOGREASE 2	Multipurpose lithium grease	- 30 to 120 °C	First lubrication & Relubrication	NLGI Grade 2. Extreme pressure grease. High stability to mechanical shear. Good resistance to water.
ESTAR 125 HT	Synthetic Ester oil	- 25 to 280 °C	Automatic (spraying or drop systems). Manual lubrication.	Synthetic ester base. Outstanding performance in high temperature. Low evaporation rate. Low rate of coking residues.
VISCOL 150 WR	Mineral oil	- 10 to 150 °C	Automatic (spraying or drop systems). Manual lubrication.	Tacky properties. Outstanding adhesive and washing out properties.
VISCOL 4200 / 75 S	Mineral oil + Solvent 4200 mm ² /s	- 5 to 150 °C	Bath / Brush	Very viscous & adhesive oil. Once the solvent is evaporated, all standard characteristics are regenerated.



RELUBRICATION AND INTERVALS

The following frequencies are guideline values according our experience.

They correspond to continuous operating conveyors which operate in a 1/4 rate of high temperature/ room temperature repartition.

TROLLEY							
Atmosphere	Recommended lubricant	Nature	Quantity per bearing (relubrication)				Cadence of lubrication in operating hour
			2" Full ball	2" With cage	3"	4"	
from - 30 to 120° c	LOGREASE 2	Grease	2 g	3 g	5 g	8 g	8000
up to 150° c (water, steam...)	STARPLEX G 2	Grease	2 g	3 g	5 g	8 g	1000
	VISCOL 150 WR	Oil	0,02 g	0,02 g	0,03 g	0,04 g	100
up to 260° c (all atmospheres)	FLUOSTAR H 2 PLUS or FLUOLOG K 400	Grease	3 g	4 g	10 g	15 g	5000
up to 280° c (all atmospheres)	FLUOLOG K500	Grease	3 g	4 g	10 g	15 g	2000 à 4000
	ESTAR 125 HT	Oil	0,02 g	0,02 g	0,03 g	0,04 g	100
up to 300° c (all atmospheres)	FLUOSTAR SX 3	Grease	3 g	4 g	10 g	15 g	1000 à 2000
	FLUOSTAR CHAIN 320	Oil	0,02 g	0,02 g	0,03 g	0,04 g	100

(Warning : The preconized quantities must be respected to avoid any drops on the rails, load rollers, trays and goods)

LUBRICATION POINT EXAMPLE

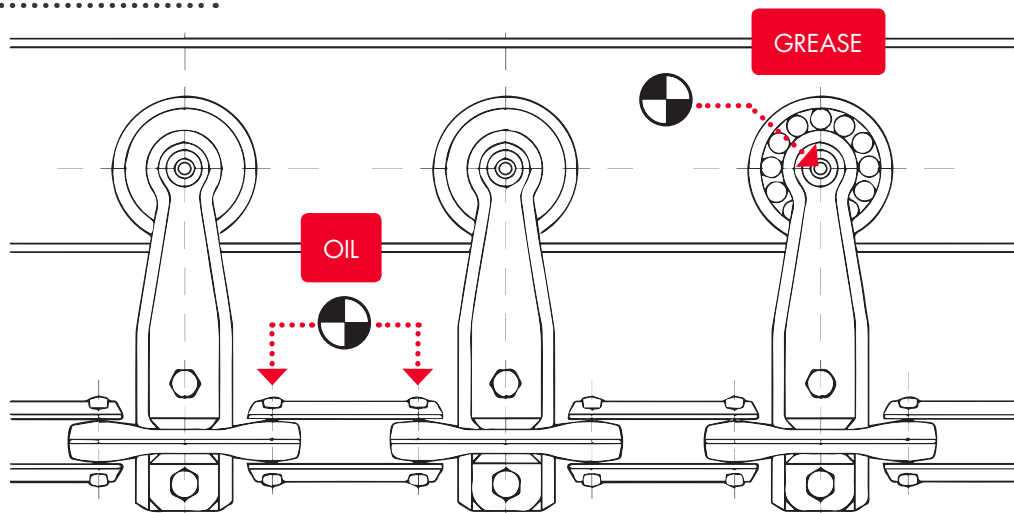

RELUBRICATION AND INTERVALS

HORIZONTAL TURN ROLLER

Atmosphere	Recommended lubricant	Nature	Quantity per bearing (relubrication)			Cadence of lubrication in operating hour
			2"	3"	4"	
- 30 to 120° C	LOGREASE 2	Grease	5 g	15 g	20 g	10 000
up to 150° C (water, steam...)	STARPLEX G 2	Grease	5 g	15 g	20 g	1000
up to 300° C (any atmospheres)	FLUOSTAR SX 3	Grease	7 g	13 g	13 g	1500

HORIZONTAL TURN WHEEL

Atmosphere	Recommended lubricant	Nature	Quantity per bearing (relubrication)			Cadence of lubrication in operating hour
			2"	3"	4"	
- 30 to 120° C	LOGREASE 2	Grease	40 g	65 g	65 g	10 000
up to 150° C (water, steam...)	STARPLEX G 2	Grease	40 g	65 g	65 g	1000
up to 300° C (any atmospheres)	FLUOSTAR SX 3	Grease	70 g	120 g	120 g	1500

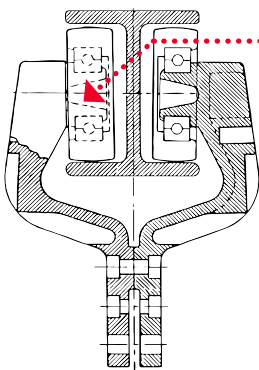

Remark : Parts most exposed to high temperature (e.g.: load rollers in oven) have to be lubricated more often.

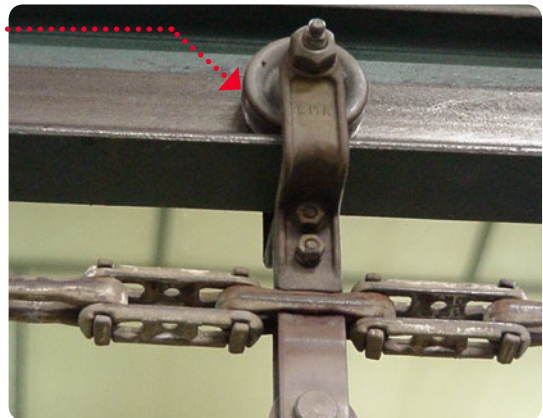



RELUBRICATION AND INTERVALS

CATERPILLAR DRIVES

Elements	Recommended lubricant	Method of lubrication	Cadence of lubrication in operating hour
Chains "CATERPILLAR"	VISCOL 4200 / 75 S	Bath	5000
Chains "CATERPILLAR"	VISCOL 150 WR	Brush	500
Bearings	LOGREASE 2	Lubrication System	5000

CHAINS

Atmosphere	Recommended lubricant	Quantity per bearing (relubrication)			Cadence of lubrication in operating hour
		2"	3"	4"	
up to 150° C	VISCOL 150 WR *	15 g	25 g	35 g	100
up to 280° C	ESTAR 125 HT *	15 g	25 g	35 g	100
up to 300° C	FLUOSTAR CHAIN 320	15 g	25 g	35 g	100

* Also available in Spray

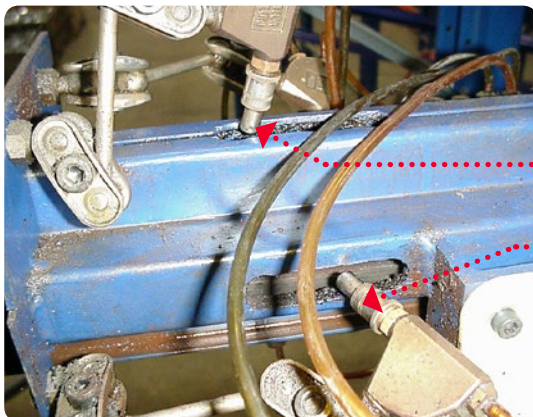
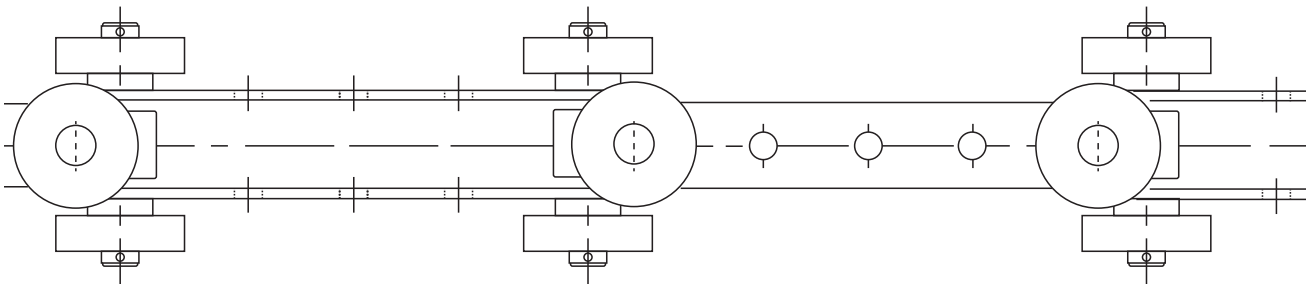

OIL SPRAYING NOZZLES

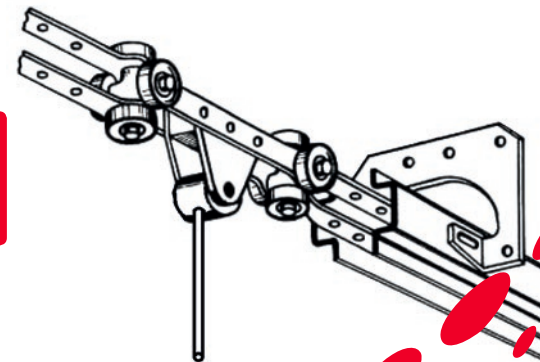

LUBRICATION ENGINEERING



LUBRILOG

LUBRILOG SA

Z.I. des Chasses - 18 rue Nicolas Appert - BP 60261 - F. 26106 Romans Cedex
T : +33 (0)4 75 45 26 00 - F : +33 (0)4 75 45 18 65 - e-mail : contact@lubrilog.fr

WWW.LUBRILOG.FR